

# Digital Tilt Sensors OS3D-DTS

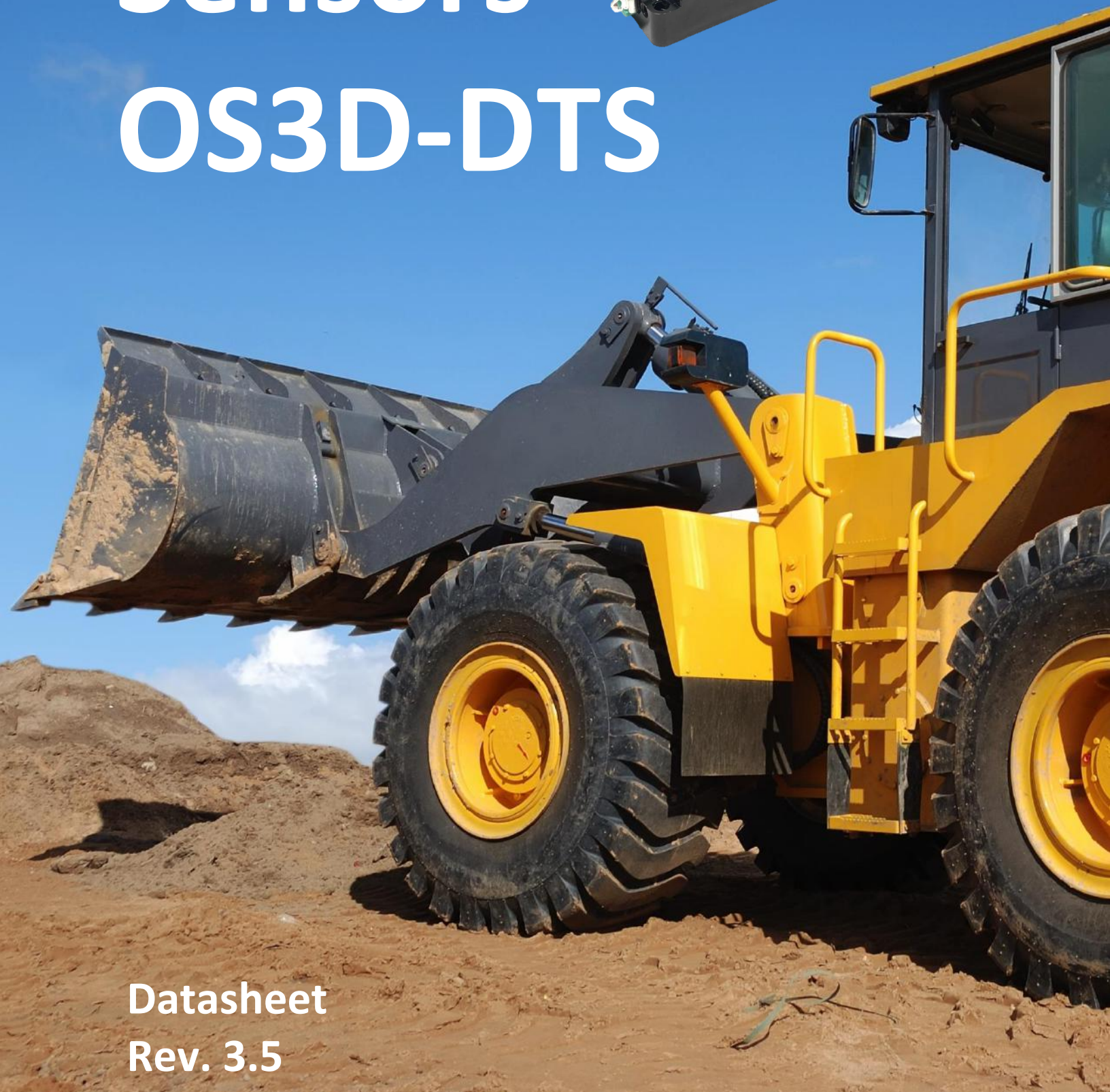

Datasheet  
Rev. 3.5

The **Inertial Labs OS3D-DTS** is an ultra high accuracy, miniature MEMS Digital Tilt Sensors, designed for test & measurement, industrial, manufacturing, R&D, aerospace static and dynamic applications.

**OS3D-DTS** includes tri-axial MEMS Gyroscopes and tri-axial high precision MEMS Accelerometers. The **OS3D-DTS** also comes equipped with an onboard processor and embedded inclination and tilt algorithms allowing for direct integration into systems without interfacing a PC.

## Applications



- High-precision Geotech
- Precision Tilt Measuring
- Pavement Profiling Rigs
- Vehicle Wheel Alignment
- Oil & Gas, Riser Tilt Monitoring
- Platform Leveling and Positioning
- Industrial Automation and Control
- Robotics and Electro Optical Systems
- Construction & Agricultural Equipment
- Railway Track Alignment & Maintenance
- Solar Tracking, Mobile Cranes and Radars

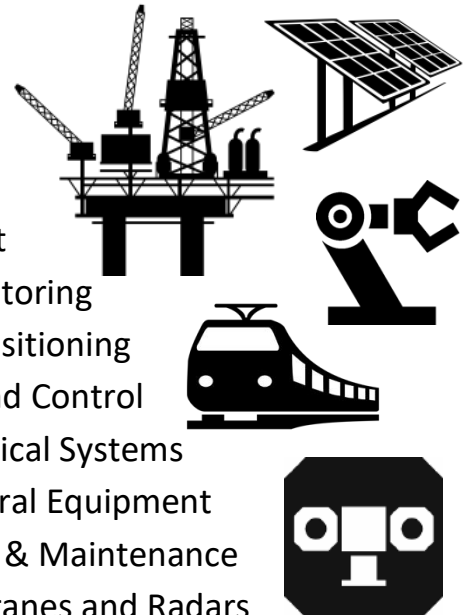

## KEY FEATURES AND FUNCTIONALITY

- Export classification: EAR99 (No License Required)
- Advanced MEMS Gyroscopes and Accelerometers
- 0.01 deg Pitch & Roll resolution
- 0.05 deg Pitch & Roll accuracy
- -40degC...+85degC operational temperature range
- Robust and Rugged Enclosure
- High Shock and Vibration Tolerance
- Affordable price
- Fully calibrated in operational temperature range
- Real-time Pitch and Roll orientation information
- Small size, lightweight and low power consumption
- Environmentally sealed (IP67)

## OS3D-DTS Specifications

Parameter	Units	Value		
Output signals		Pitch, Roll, Accelerations, Angular rates		
Start-up time	sec	<1		
<b>Pitch &amp; Roll</b>				
Range: Pitch	deg	±90		
Range: Roll	deg	±180		
Angular Resolution	deg	0.01		
Static Accuracy, RMS	deg	0.05		
Dynamic Accuracy, RMS	deg	0.08		
<b>Sensors</b>				
		<b>Gyroscopes</b>	<b>Accelerometers</b>	
Measurement range		±1864 deg/s	±15 g	±40 g
Bandwidth		up to 200 Hz	up to 200 Hz	up to 200 Hz
Bias in-run Stability (Allan Variance)		<8 deg/hr	0.03 mg	0.05 mg
Bias instability (in temp. range, RMS)		0.2 deg/sec	1.1 mg	1.5 mg
Bias one-year repeatability		0.5 deg/sec	2.0 mg	2.5 mg
Scale Factor Accuracy		500 ppm	700 ppm	850 ppm
SF one-year repeatability		1000 ppm	1400 ppm	1700 ppm
Random Walk		0.36 deg/vhr	0.045 m/sec/vhr	0.06 m/sec/vhr
Power Spectral Density		0.006 deg/vHz	0.08 mg/vHz	0.1 mg/vHz
Non-linearity		0.05 %	0.05 %	0.05 %
Axis misalignment		0.15 mrad	0.15 mrad	0.15 mrad
<b>Environment</b>				
Operating temperature range	deg C	-40 to +85		
Storage temperature range	deg C	-45 to +90		
MTBF (G <sub>M</sub> +65degC)	hours	100,000		
Environmentally sealed		IP65 (version C11, 12, 21, 22) / IP67 (version C5)		
<b>Electrical</b>				
		<b>Version C11, C12, C21, C22</b>		<b>Version C5</b>
Supply voltage	V DC	5V to 25V		9V to 36V
Current consumption	mA, V	24 mA @ 5V / 5 mA @ 25V		75 mA @ 12 V
Power Consumption	W	0.125 W (typical)		0.9 W (typical)
Connector type	-	G125-MV11005L1P by HARWIN		Binder Series 723
Output Interface	-	RS-232 or RS-422		RS-232, Ethernet
Baud Rate	bps	Up to 3M (RS-422) Up to 1M (RS-232)		Up to 1M (RS232)
Update rate	Hz	500		500
<b>Physical</b>				
		<b>Version C11, C12, C21, C22</b>		<b>Version C5</b>
Size	mm	26.5 × 19.5 × 8.4		120 x 50 x 53
Weight	gram	9		220



OS3D-DTS part number structure: OS3D-DTS-GXXXX-AXX-TGA-CXX-VXX.X

Model	Gyroscopes range	Accelerometers range	Temperature calibration	Type of enclosure	Version	Type of interface
OS3D-DTS	G1864	A15 A40	TGA	C11 C12 C21 C22 C5	V10 V11	VX.1 VX.2
Digital Tilt Sensor	±1864 deg/s	±15 g ±40 g	Gyroscopes & Accelerometers are calibrated over operational temperature range	C0: OEM C11: Aluminum case, mounting option #1 mating option #1 C12: Aluminum case, mounting option #1 mating option #2 C21: Aluminum case, mounting option #2 mating option #1 C22: Aluminum case, mounting option #2 mating option #2 C5: IP-67 sealed enclosure	V10: filters-on V11: filters-off	VX.1: RS-232 VX.2: RS-422  For C5 models: VX.3: Ethernet VX.13: RS-232 & Ethernet

### OS3D-DTS mechanical interface drawing (version C11, C12, C21, C22)

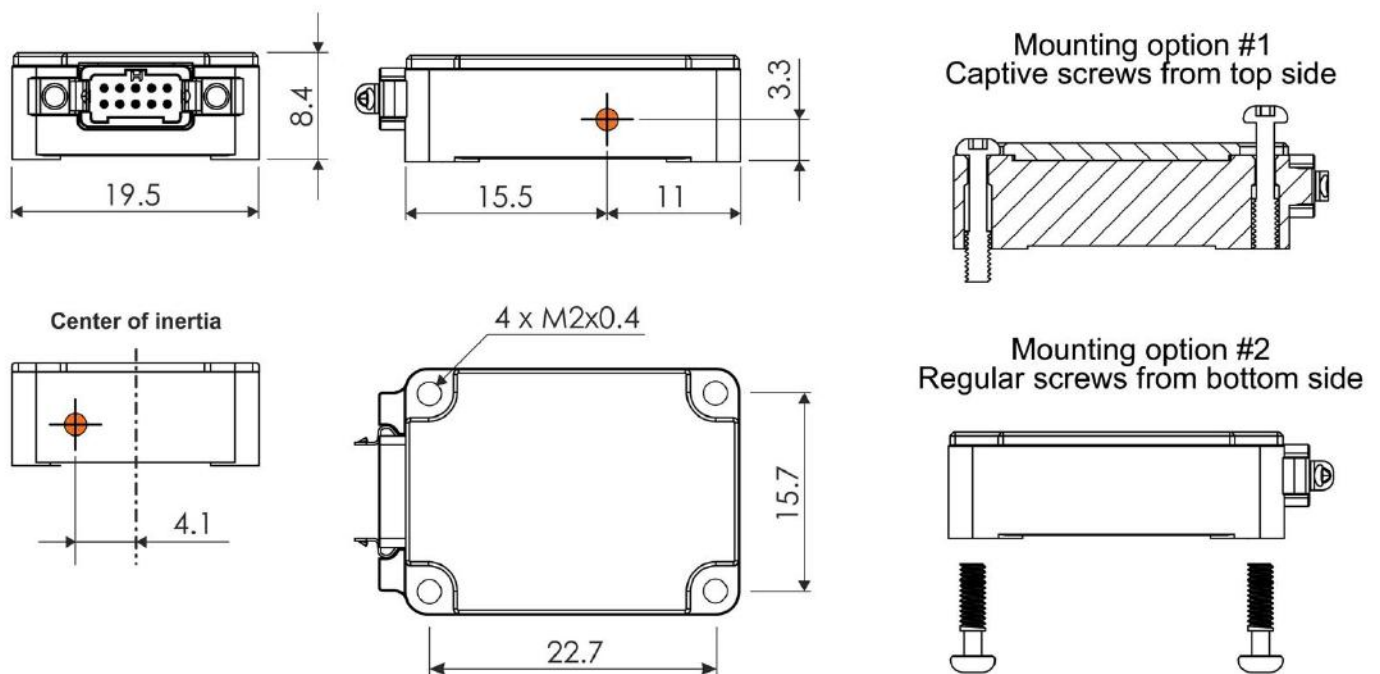

**Note 1:** All dimensions are in millimeters.

**Note 2:** All dimensions within this drawing are subject to change without notice. Customers should obtain final drawings before designing any interface hardware.

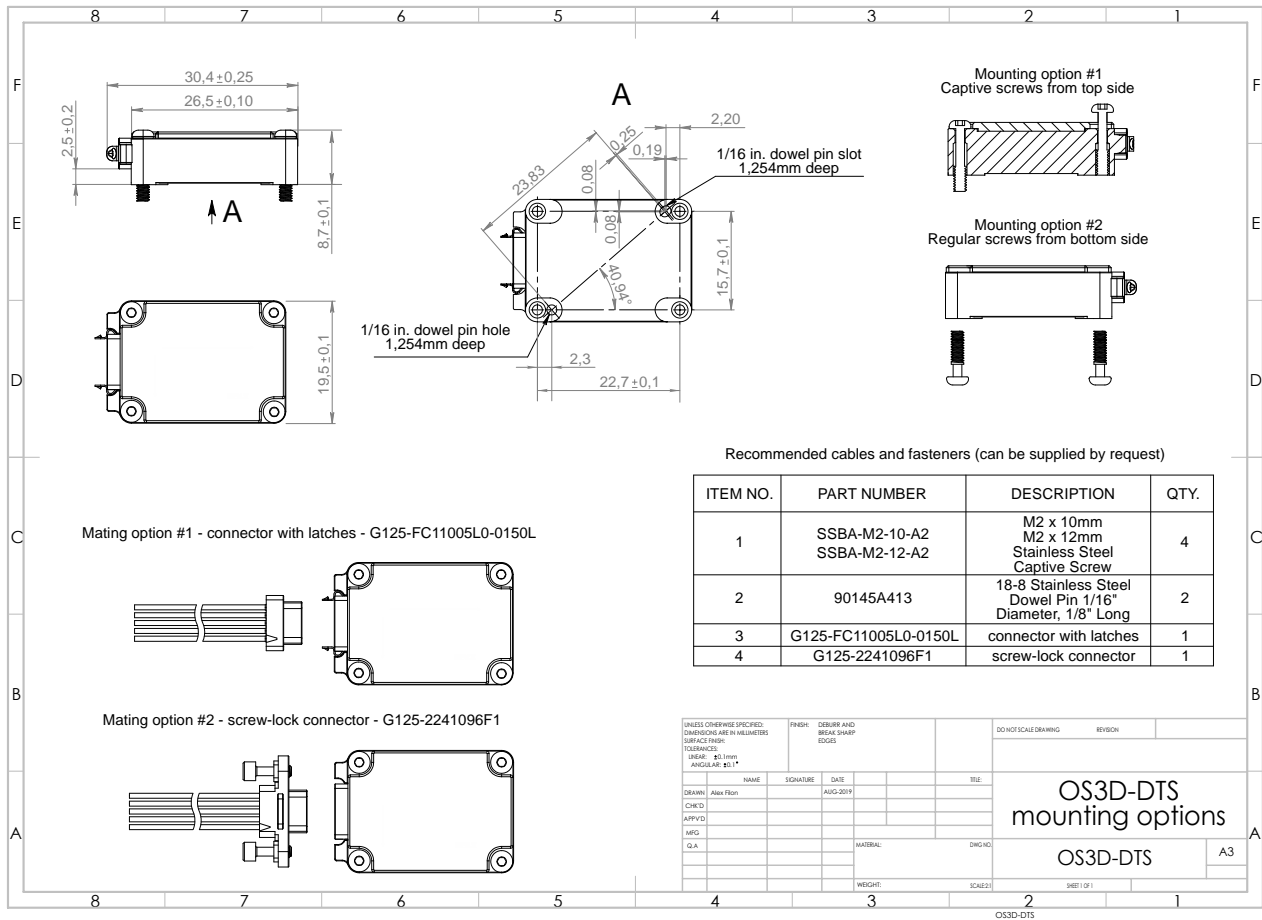

## OS3D-DTS electrical interface description (version C11, C12, C21, C22)

G125-MV11005L1P by HARWIN  
G125-MV11005L0P by HARWIN

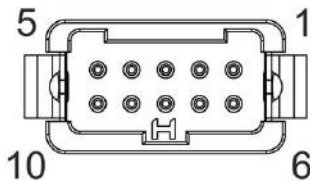

Mating option #1 - connector with latches - G125-FC11005L0-0150L

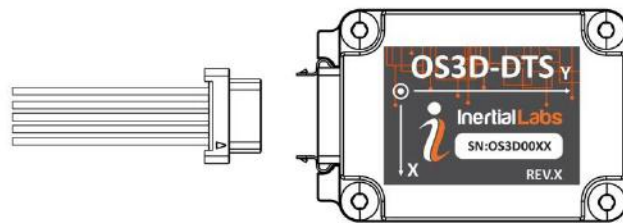

1	POWER	Power Supply Input (Note 3)
2	RS232-Tx	RS232 Transmitter Output (Note 2)
3	RS232-Rx	RS232 Receiver Input (Note 2)
4	RS422-A	RS-422 Non-Inverting Input
5	RS422-B	RS-422 Inverting Input
6	GROUND	Power Supply Return
7	TOV	3V3 TTL Time of validity output
8	EXTRIG	3V3 TTL External trigger input
9	RS442-Y	RS-422 Non-Inverting Output
10	RS422-Z	RS-422 Inverting Output

Note 1: Screw-lock is available upon customer request

Note 2: 3V3 TTL UART is available upon customer request

Note 3: The supply voltage range is 5V-25V.

Mating option #2 - screw-lock connector - G125-2241096F1 (Note 1)

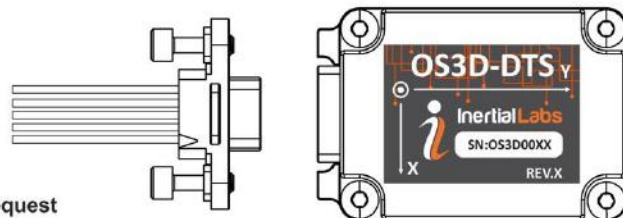

OS3D-DTS mechanical interface drawing (version C5)

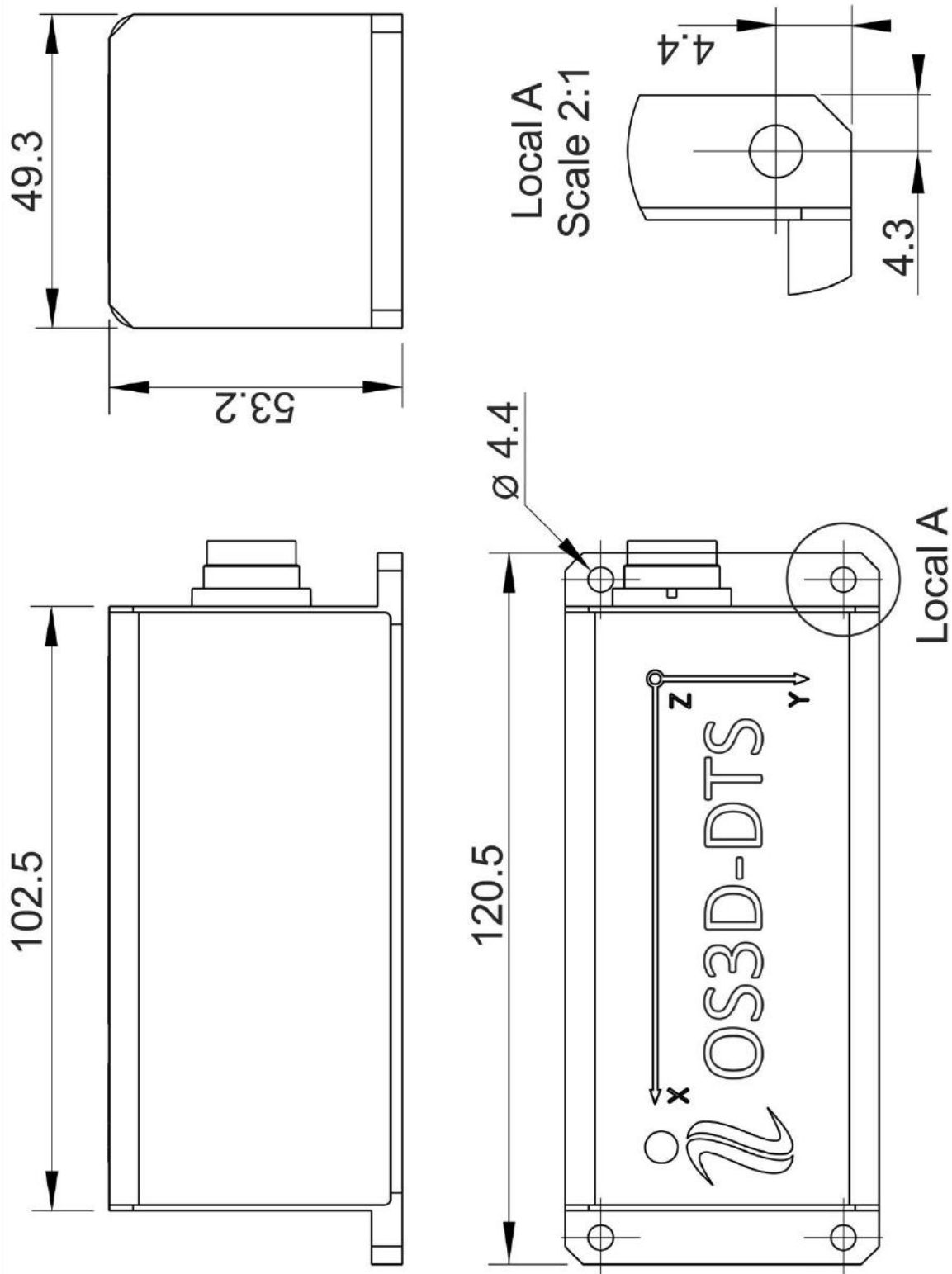

## OS3D-DTS electrical interface description (for version C5 only)

