

# WAVE Sensors

WS-E  
WS-PD

- 5 cm Wave Height Accuracy
- 0.1 sec Wave Period Accuracy
- 0.5° Wave Direction Accuracy
- 0.02° Pitch & Roll accuracy
- 5 cm / 5% Heave accuracy
- IP67 Environmentally Sealed
- Optional Internal Data Logger
- Compatible with Buoy's Controllers



WS - Enhanced  
WS - Professional Dual

Datasheet  
Revision 1.0



 **Inertial Labs**  
Attitude is Everything

Inertial Labs has developed **Wave Sensors (WS)** to meet industry wave statistics requirements and also generates the spectral data as a complete set of Fourier coefficients and energies. **Wave Sensors (WS)** are an enhanced, high-performance strapdown Wave, Direction & Motion Sensors, that determines Significant Wave Height, Max Wave Height, Wave Period, Wave Direction, Wave Energy, Directional Width, Fourier Coefficients, Mean Spread Angle, Heading, Pitch, Angular Rates, Accelerations, Magnetometer Data, Temperature, Heave, Heave Velocity and Position for any device on which it is mounted.



The Inertial Labs **Wave Sensors (WS)** Units utilizes solid state 3-axes each of precision accelerometers, magnetometers, gyroscopes and barometric sensors to provide accurate Wave Characteristics as well as Heave, Sway, Surge, Pitch and Roll of the device under measure.

The **Wave Sensors (WS)** can easily be integrated with a buoy or floating platform controller to transmit data in real time.

Through a combination of proven sector expertise and a continued investment in technological innovation, Inertial Labs delivers the optimum balance of price and performance ratio solutions for its customers.

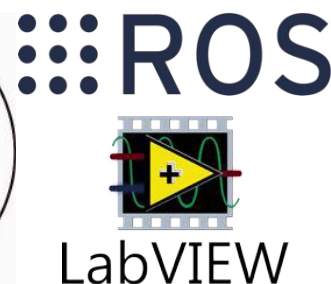
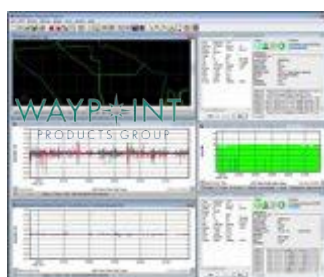
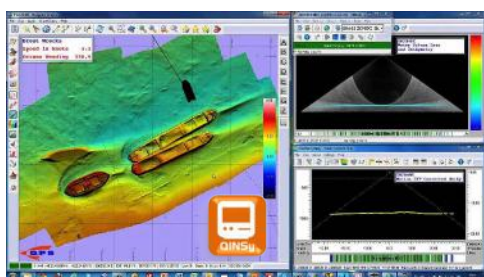

Our **Wave Sensors** featuring developed few micro g Bias in-run stability Advanced Micro Electro Mechanical System (AMEMS)-based accelerometers. New generation of Inertial Labs 1 deg/hr Bias in-run stability MEMS-based gyroscopes are an ideal solution for demanding marine applications, with their electronic nature negating the problems associated with expensive mechanical gyro solutions, as well as those based on fiber optic (FOG) technology. Inertial Labs MEMS gyroscopes set the standard for the industry, with our high-end **Wave Sensors** featuring gyros that enable sector-leading accuracy and reliability standards.

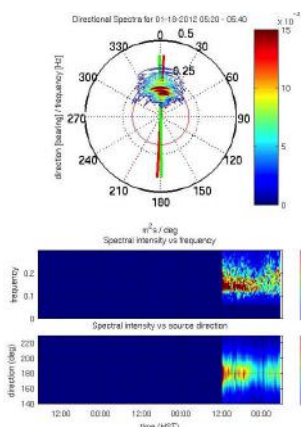

Measured Parameters	WS-E	WS-PD
	Enhanced	Professional Dual
Wave Height (meters)	✓	✓
Wave Period (sec)	✓	✓
Wave Direction (deg)	✓	✓
Heave, Surge, Sway (% / meters)	✓	✓
Pitch & Roll (deg)	✓	✓
Gyro-magnetic Heading (deg)	✓	✓
High Precision GNSS Heading (HDT) (deg)		✓
DGPS/RTK Position (meters)		✓

Parameter	Units	WS-E (Enhanced)	WS-PD (Professional Dual)
Certification	-	ABS	
Basic Output Signals	-	<ul style="list-style-type: none"> <li>Significant Wave Height; Max Wave Height; Wave Period; Wave Direction; Wave Energy; Fourier Coefficient; Directional Width; Mean Spread Angle; Heading; Pitch; Angular Rates (X,Y,Z), Accelerations (X,Y,Z); Magnetometer Data; Temperature; Heave; Heave Velocity</li> </ul>	
Input Signals	-	<ul style="list-style-type: none"> <li>Doppler Velocity Log; Gyro Compass; External Heading; External Position; External GNSS</li> </ul>	
Output Data Formats	-	<ul style="list-style-type: none"> <li>Binary; TSS-1, NMEA 0183 ASCII; Kongsberg /Seatex; SMC; Teledyne TSS*</li> </ul>	
Compatibility	-	<ul style="list-style-type: none"> <li>Buoy; SBES/MBES; Doppler Velocity Logger (DVL); Helideck Monitoring System (HMS)</li> <li>HYPACK; QINSY; Novatel Inertial Explorer software*</li> <li>DP-1; DP-2; DP-3; AHC; Survey systems</li> </ul>	
Internal Data Logger	-	Optional (8 GB)	Optional (8 GB)
Update Rate	Hz	1-200 (User Settable)	1-200 (User Settable)
IP Grade	-	IP67	IP67
<b>Wave Period</b>			
Range	seconds	1 to 30	1 to 30
Resolution	seconds	0.01	0.01
Accuracy	% (seconds)	1 (0.1)	1 (0.1)
Wave Mean Period	seconds	Yes	Yes
Wave Peak Period	seconds	Yes	Yes
<b>Wave Height</b>			
Range	meters	±300	±300
Resolution	meters	0.001	0.001
Accuracy	% (meters)	5 / (0.05)	5 / (0.05)
<b>Wave Direction</b>			
Range	deg	0 to 360	0 to 360
Resolution	deg	0.01	0.01
Accuracy	deg	1	0.5
Wave Mean Direction	deg	Yes	Yes
Wave Peak Direction	deg	Yes	Yes
<b>Wave Characteristics</b>			
	-	Fourier Coefficient Spectrum; Mean Spreading Angle; Directional Width; Long Crestedness Parameter; Mean Wave Direction Spectrum; Principal Wave Direction Spectrum; Average Wave Power; Number of Zero Crossings	
<b>Pitch and Roll</b>			
Range	deg	±90, ±180	±90, ±180
Angular Resolution	deg	0.01	0.005
Accuracy	deg	0.02	0.02
<b>Heading</b>			
Range	deg	0 to 360	0 to 360
Angular Resolution	deg	0.01	0.001
Accuracy	deg	0.6	0.05
<b>Heave, Surge and Sway</b>			
Measurement Range	meters	±300	±300
Resolution	meters	0.01	0.01
Real Time Accuracy, RMS	% / (meters)	5 / (0.05)	5 (0.05)
<b>Positions and Velocity</b>			
Horizontal position accuracy (DGPS), RMS	meters	External Source	0.4
Horizontal position accuracy (RTK), RMS	meters	External Source	0.01 + 1 ppm
Velocity Accuracy, RMS	meters/sec	External Source	0.03
<b>GNSS Receiver</b>			
Number of GNSS Antennas	-	External Source	Dual
Supported navigation signal	-	External Source	GPS L1/L2, GLONASS L1/L2, BEIDOU B1/B2, GALILEO E1/E5, QZSS L1/L5, SBAS, DGPS, RTK
Velocity accuracy, RMS	meters/sec	External Source	<0.03
Initialization time	seconds	External Source	<50 (cold start), <30 (hot start)
<b>Environment</b>			
Operating temperature	deg C	-40 to +70	-40 to +70
Storage temperature	deg C	-50 to +85	-50 to +85
MTBF	hours	250,000	250,000
Vibration	-	IEC 60945/EN 60945	IEC 60945/EN 60945
<b>Electrical</b>			
Supply voltage	V DC	9 to 36	9 to 36
Power consumption	Watts	1.4	2.6
Compliance to EMCD, immunity/emission	-	IEC 60945/EN 60945	IEC 60945/EN 60945
Output Data Formats	-	Binary; TSS-1; NMEA 0183 ASCII; Kongsberg/Seatex; SMC; Teledyne TSS*	
Interface	-	RS-232; RS-422; Ethernet	RS-232; RS-422; Ethernet
<b>Physical</b>			
Size	mm	120 x 50 x 53	120 x 50 x 53
Weight	gram	320	320

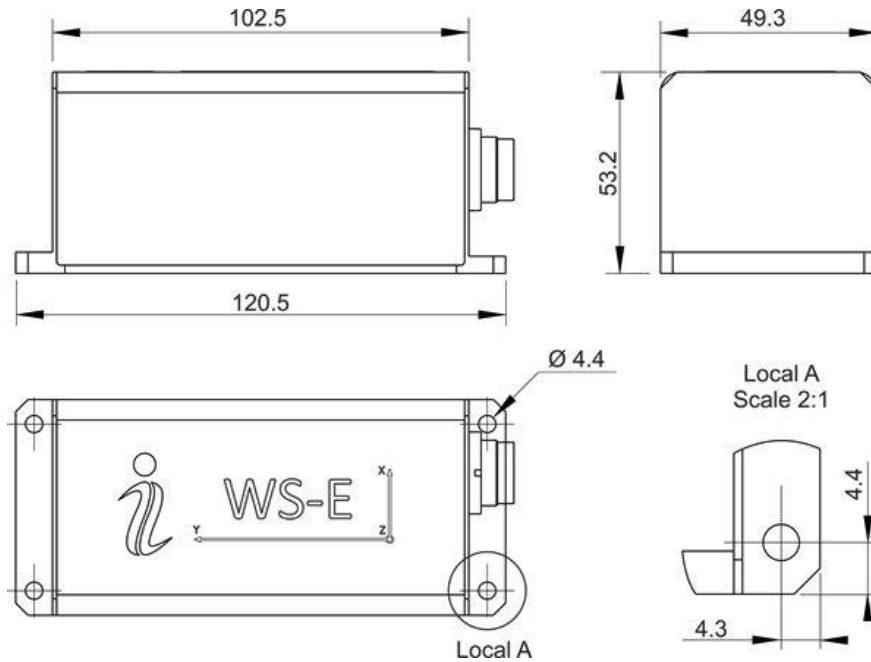
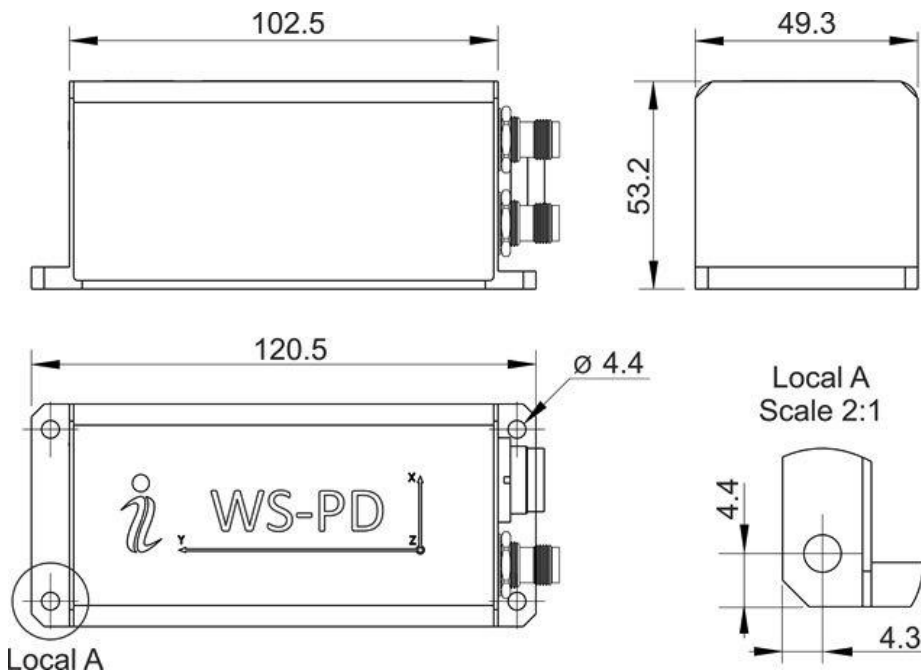
**Wave Sensor (WS-E) Mechanical Interface Drawings**

**Wave Sensor (WS-PD) Mechanical Interface Drawings**

**Notes:**

1. All dimensions are in millimeters.
2. All dimensions within this drawing are subject to change without notice. Customers should obtain final drawings before designing any interface hardware.
3. Data connector type: Binder Series 723. Male receptacle, shielded, rear-mounting
4. GNSS connector type (WSU-PD): TNC-Female

■ \* Trademark Legal Notice: All product names, logos, and brands are property of their respective owners. All company, product and service names used in this document are for identification purposes only. Use of these names, logos, and brands does not imply endorsement. Kongsberg/Seatex, Ship Motion Control SMC, Teledyne TSS , R2Sonic, WAASP, EdgeTech, NORBIT, IMAGENEX, HYPACK, QINSY, Novatel Inertial Explorer are trademarks of Kongsberg/Seatex, Ship Motion Control SMC, Teledyne TSS , R2Sonic, WAASP, EdgeTech, NORBIT, IMAGENEX, HYPACK, QINSY, Novatel its affiliates or its respective owners, registered or used in many jurisdictions worldwide.